

Function

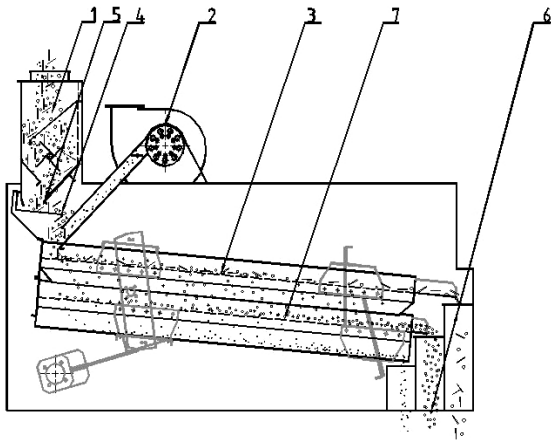

The raw material is conveyed down into the inlet bin (1). There must always be material in this bin to ensure an even distribution over the presuction area (extra equipment) (2) / top screen layer (3). The feeding device (4) doses the quantity of raw material from the inlet bin to the presuction unit / top screen box via a regulating damper.

The screen systems

The screen boxes are suspended in the chassis each by 2 plastic springs and 2 torsion elements. The screen boxes are driven by the latter.

Each screen box contains 2 ball screens with rubber balls and 2 screens. The screens are interchangeable. Different cleaning and grading tasks may require other screens in each screen layer.

The individual screens are cleaned by means of rubber balls. The balls are placed in a special ball screen divided into sections each with 5 rubber balls, 120 balls in all.

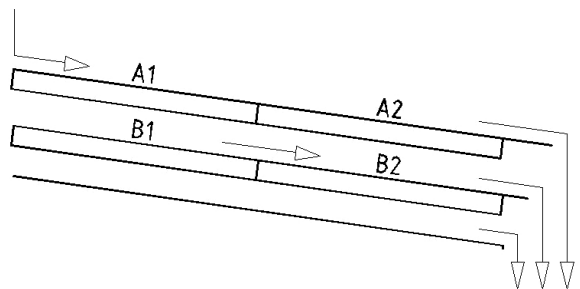

Guiding capacities		UniSeed	DuoSeed
Precleaning, wheat	t/h	30	60
Malting barley grading	t/h	8	16
Fine cleaning, wheat	t/h	4	8

Specifications		UniSeed	DuoSeed
Screen width	mm	1000	1000
Screen length	mm	998	998
Number of screens	pcs.	4	8
Screen area	m ²	4	8
Motor, screens	kW	0.75	1.5
Motor, feed roller	kW	-	0.25
Motor, clipper-de-awner (option)	kW	2.2	2.2
Motor, presuction unit (option)	kW	1.1	1.1
Width	mm	1290	1290
Width incl. motors	mm	1500	1500
Length	mm	2465	2480
Height	mm	1675	2850
Weight	kg	930	1860