

Data sheet

GrainPlus

LAGA

Grain Logistics

Processing
Systems



Intake capacity (depends on input contamination)

Product	Screens*	GrainPlus 05	GrainPlus 10	GrainPlus 20
Wheat 0.75 t/m ³ 18% H ₂ O	PS: Ø 8 mm MS: 2,25 x 23 mm	12 t/h	25 t/h	50 t/h
Feed barley 0.65 t/m ³ 18% H ₂ O	PS: Ø 8 mm MS: 2,25 x 23 mm	10 t/h	20 t/h	40 t/h
Rapeseed 0.6 t/m ³ 14% H ₂ O	PS: Ø 3,5 mm MS: 1 x 23 mm	6 t/h	12 t/h	25 t/h
Maize (corn) 0.75 t/m ³ 15% H ₂ O	PS: Ø 13 mm MS: 2,55 x 23 mm	12 t/h	25 t/h	50 t/h
Maize (corn) 0.75 t/m ³ 35% H ₂ O	PS: Ø 13 mm MS: ---	6 t/h	12 t/h	25 t/h
Soya beans 0.75 t/m ³ 18% H ₂ O	PS: Ø 13 mm MS: 2,55 x 23 mm	15 t/h	30 t/h	60 t/h
Paddy 0.55 t/m ³ 18% H ₂ O	PS: 5,5 x 23 mm MS: 1,4 x 23 mm	2 t/h	5 t/h	10 t/h
White rice 0.75 t/m ³ 12% H ₂ O	PS: 5,0 x 23 mm MS: 1,25 x 23 mm	3 t/h	6 t/h	12 t/h

* PS: Preliminary screen; MS: Main screen

Included

- Intensive aspiration at the outlet for removing light impurities
- Screening machine with circular vibrating screens, including 1 set of screens with rubber-ball cleaning
- Smooth-action manual flap for regulation of aspiration at the outlet

Data sheet GrainPlus

LAGA

GrainPlus – without inlet aspiration

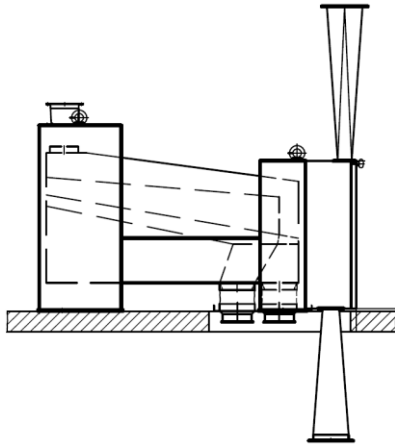

GrainPlus - with inlet aspiration

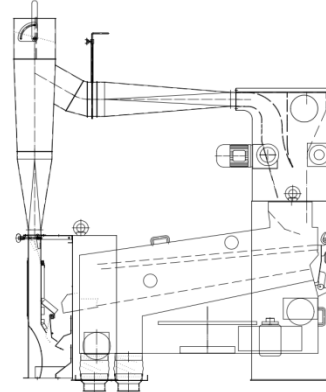

	Unit	GrainPlus 05	GrainPlus 05-E	GrainPlus 10	GrainPlus 10-E	GrainPlus 20	GrainPlus 20-E
Working width	mm	500	500	1,000	1,000	2,000	2,000
Screen area							
Total	m ²	1.5	1.5	3	3	6	6
Preliminary screen area		0.75	0.75	1.5	1.5	3	3
Main screen area		0.75	0.75	1.5	1.5	3	3
Connected load							
Screen box	kW	0.75	0.75	0.75	0.75	0.75	0.75
Others					0.75		0.75
Aspiration connection							
Inlet aspiration (at 30mmWC)	m ³ /min	---	15	---	30	---	70
Outlet aspiration (at 30mmWC)		35	35	70	70	120	120
Total weight							
Without magnet	kg	ca. 680	ca. 820	ca. 870	ca. 1,230	ca. 1,330	ca. 1,740
With magnet		ca. 700	ca. 840	ca. 920	ca. 1,290	ca. 1,390	ca. 1,800
Dimensions							
Length	mm	2,240	2,240	2,240	2,240	2,240	2,240
Width		910	910	1,410	1,410	2,410	2,410
Height		1,480	2,150	1,480	2,150	1,480	2,150
Optional magnet at outlet		yes	yes	yes	yes	yes	yes
Inlet aspiration		---	yes	---	yes	---	yes

The values are non-binding, technical changes reserved. In cramped mounting conditions the dimensions of the universal aspirators should be reviewed in the order again.