

TORNUM Clean Air Control, 22 kW



Integrated dust cleaning – an efficient solution

TORNUM Clean Air Control is a powerful 22 kW fan with an integrated dust cleaner, optimised for maximum air flow, minimum noise and efficient dust separation in grain handling applications. It removes 95 % of dust and lighter impurities from your grain.

Design and function

- The casing is fully galvanized for efficient corrosion protection.
- Available in horizontal or vertical configuration (horizontal version shown).
- Large inspection hatches makes servicing and inspection easy.
- An air damper on the inlet ensures an accurate air flow regulation.
- Available with optional voltages and thermal switch.
- The specially designed impeller optimises air flow with minimal noise (see noise data on the next page).





Outlet options:

- Safety net (always included)
- Ducting pipe, Ø 1000 mm
- Silencer, part no. 688 408 alt. 688 409
- Rain cover (only for vertical configuration), part no. 960 200

Part numbers:

Horizontal configuration: 960 300

Vertical configuration: 960 301

Noise data*, dB(A), and measurements, mm:

Frequency	31.5 Hz	62.5 Hz	125 Hz	250 Hz	500Hz	1kHz	2kHz	4kHz	8kHz	Total
	54	64	74	89	93	94	88	79	77	98

*Sound pressure measured 1m behind the fan.

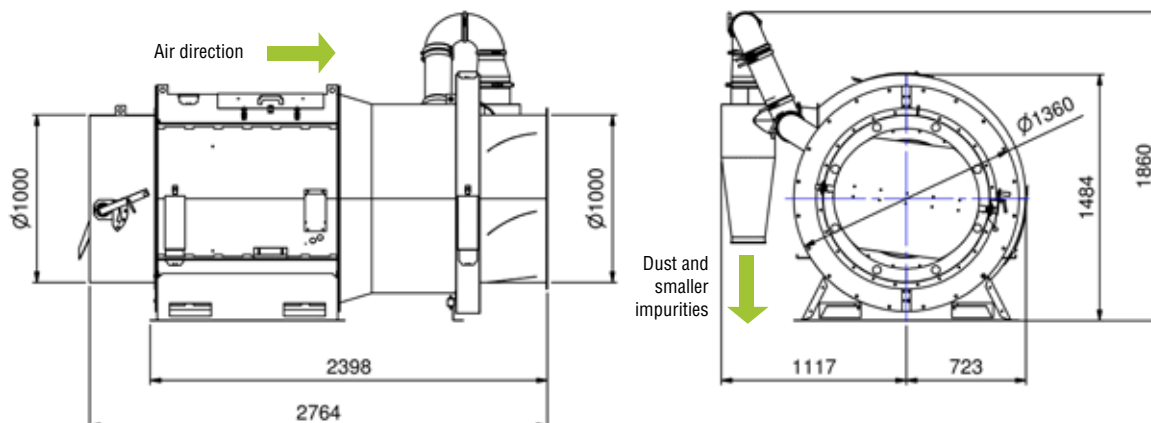

TORNUM[®]