

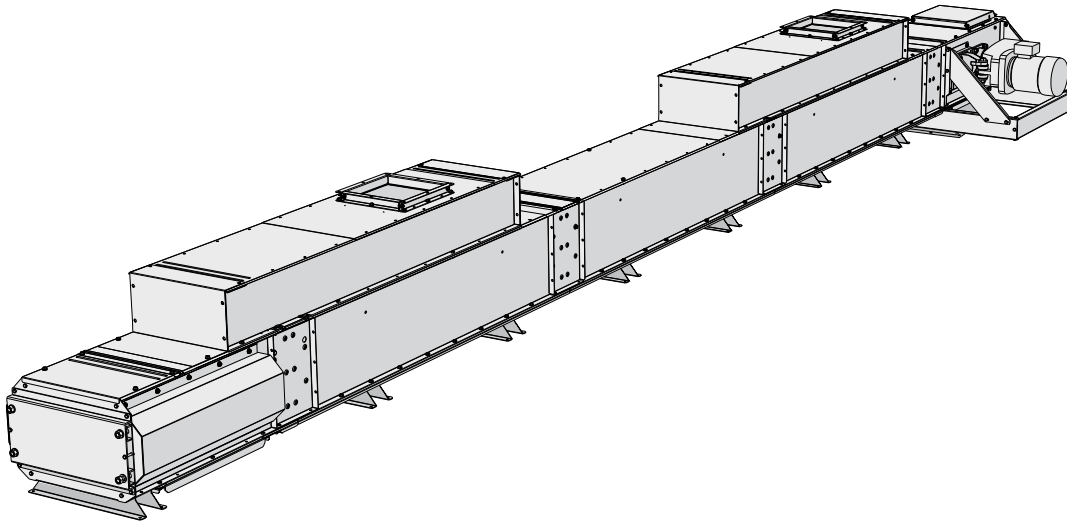

**SKANDIA
ELEVATOR**



Our machines are designed for outdoor use. We only use galvanised steel plate, and join the parts by means of clamp riveting and screwing in order to keep the surface layer intact. Edges are bent down, joints and seams overlap and many parts are embossed in order to prevent water penetration. The most exposed joints are also sealed with rubber strips or silicone. The products in the H-LINE are designed for plants with intense operation all year round.



KTHb
50/64-70/64

The bottom conveyor KTHb is adapted in terms of capacity to transport material from storage bins/silos or from another Skandia bottom conveyor to a Skandia belt & bucket elevator. When feeding from a storage bin/silo a raised inlet is used that is self-regulating, which prevents overfilling.

STANDARD EQUIPMENT:

- > Direct-mounted gearbox motor
- > Pop up overloading flap/inspection hatch with safety switch
- > Outlet hopper for the drive
- > Chain tensioner with variable end face for extra cleanliness
- > Bottom clean out hatch in tail end
- > Journalled chain return rollers of steel
- > Permanently lubricated bearings
- > Chain and flight of steel with clean-out flight of PE (polyethylene)
- > Plastic wearing surfaces on top of the bottom plate

ACCESSORIES:

- > Self-regulating raised inlet/Inlet hopper
- > Connections, slides & hoppers
- > Chain guard
- > Intermediate section with sight glass on both sides
- > Capacity slide for fine-grained materials



Pop up overloading flap/inspection hatch with safety switch.

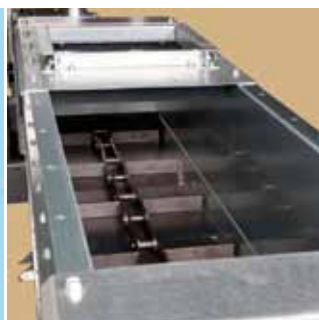

Self-regulating raised inlet.

**GALVANISED
ENERGY EFFICIENT
SERVICE FRIENDLY
COMPACT
RELIABLE
EASILY MOUNTED**

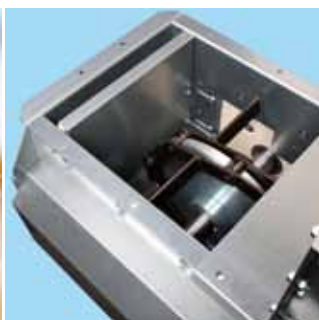

Variable end face for extra cleanliness.

**THE
LEADING
COMPANY**

KTHb DIMENSIONAL DRAWING

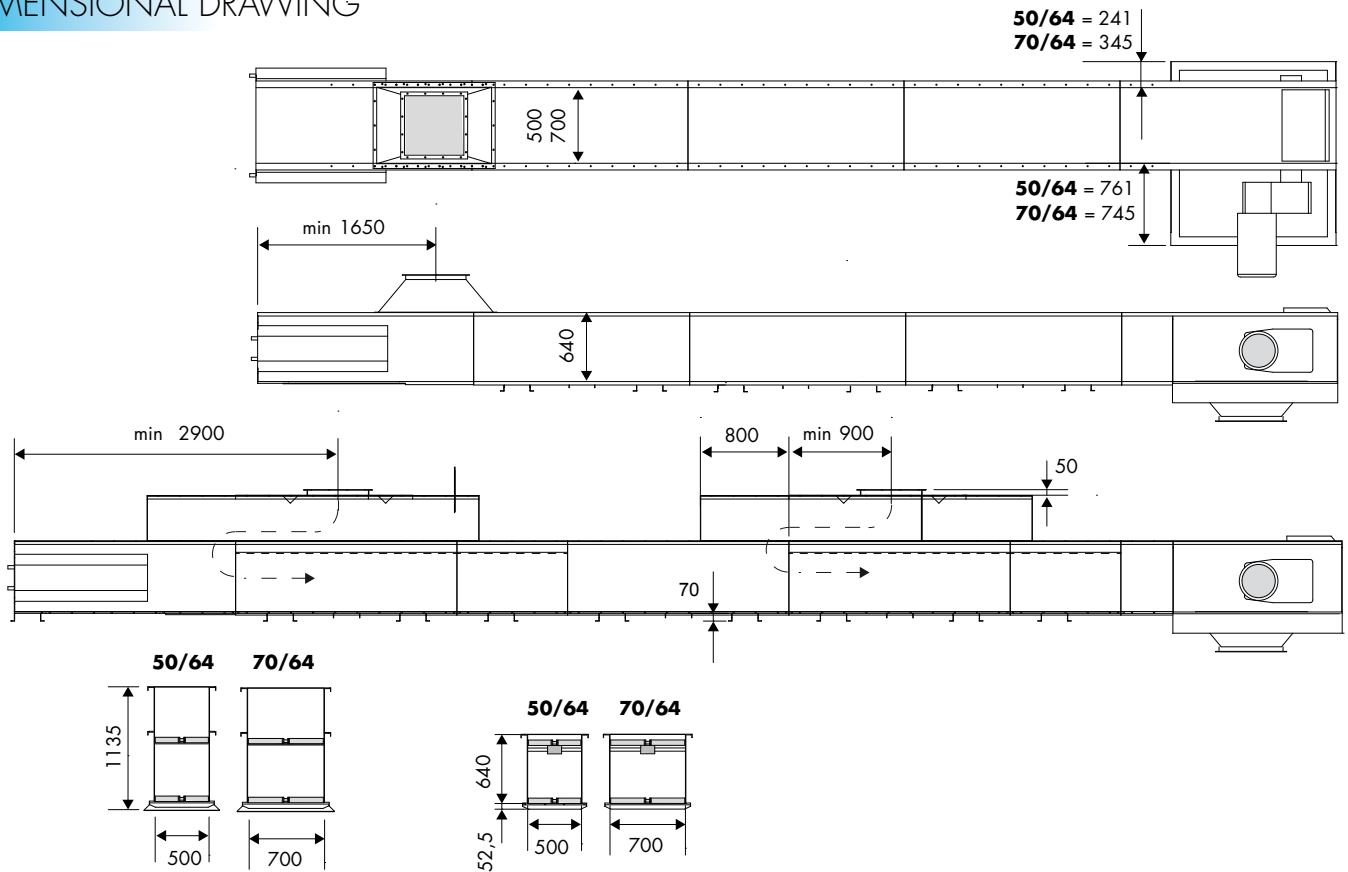

All drawings are available in CAD format.

KTHb BOTTOM CONVEYOR

		50/64	70/64	70/64
		400 t/h	500 t/h	600 t/h
Capacity for 750 kg/m ³	t/h	354-399	460-517	548-592
Capacity	m ³ /h	472-532	613-689	731-789
Speed	rpm	24-27	24-27	25-27
Chain speed	m/s	0.64-0.72	0.64-0.72	0.67-0.72
Conveyor chain, type			M112-M450	
Pitch/ultimate tensile strength	mm/kN		160-200/112-450	
Chain sprocket, teeth	pcs		10	
Flight, material			Steel	
Intermediate section, width/height	mm	500/640	700/640	700/640
Plate thickness drive, side plate/bottom plate	mm		8.0/2.5	
Plate thickness tail end/intermediate section, side/bottom plate	mm		4.0/2.5	
Thickness, plastic bottom	mm		10.0	
Inlet and outlet hoppers	mm	4.0/□500	4.0/□550	4.0/□550
ATEX class (standard equipment)			II 2D/OD	

